



Safety Manual SIL 2

Vibration monitoring unit Series HE205

MADE IN GERMANY

SIL2

PL-d



Proc. Cont. Eq.
for Ord. Loc.
Proc. Cont. Eq.
for Haz. Loc.



IECEE

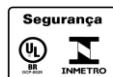

IECEX



- ATEX / IECEx zones 2/22 and 1/21
- cULus OrdLoc / HazLoc Div 2



These instructions apply to sensors version 2.0.

Safety manual

Vibration monitoring unit Type HE205

Standard and ATEX / IECEx

Version: 2025-12-04

Caution!

Before putting the product into service, the safety manual must be read and understood.

All rights reserved, including rights to translation.
Subject to modifications.

Please contact the company with any questions:

HAUBER-Elektronik GmbH
Fabrikstraße 6
D-72622 Nürtingen
Germany
Tel.: +49 (0) 7022 / 21750-0
Fax: +49 (0) 7022 / 21750-50
info@hauber-elektronik.de
www.hauber-elektronik.de

1 Contents

1	Contents.....	3
2	Scope of safety manual	4
3	Fields of application	4
4	Abbreviations and terms	5
5	Relevant norms	5
6	Safety requirements.....	6
7	Project planning	7
7.1	Safety functionality.....	7
7.2	Fail-safe state	7
7.3	Event and error code	8
7.4	Most common event and error codes	9
7.5	Exiting the fail-safe state.....	9
7.6	Event and error code table	10
7.7	Configuration safe state	11
7.8	Description of failure categories	11
8	Fault exclusions	11
9	Overview of application areas.....	12
10	Example labels.....	13
11	Connection.....	14
12	Assembly and installation	16
13	Functional description	16
13.1	Operating conditions	17
13.2	Configuration mode (alarm and limit setting).....	18
13.3	Limit values and delay times.....	19
14	Behaviour during operation and when errors occur.....	20
15	Self-diagnostic and recurring checks.....	21
16	Service life	21
17	Key indicators related to safety.....	22
18	EU Declaration of Conformity	23

2 Scope of safety manual

This safety manual for the vibration monitoring unit model HE205 applies to variants HE205.00, HE205.01 and HE205.02 with sensor version 2.0.

The variants are functionally identical. The HE205.02 and HE205.01 variants also possess certifications and labels which permit use in potentially explosive atmospheres.

3 Fields of application

The HE205 type vibration monitoring unit is used to measure and monitor absolute bearing vibrations in machines in line with DIN ISO 10816. The effective vibration speed value or effective vibration acceleration value is used as the measurement parameter.

The vibration amplitude is then evaluated in two channels independent from each other. When the adjustable vibration threshold value is exceeded, a signal will be sent to the semiconductor switches. These can be used to generate a pre-alarm and a main alarm. The HE205 type also has an analogue current output. This supplies direct current of 4-20 mA proportional to the vibration amplitude.

The semiconductor switches and current output were assessed and factored in when determining the safety functionality, using the key indicators related to safety according to the norms mentioned in the section 5.

4 Abbreviations and terms

SIL	Safety Integrity Level
HFT	Hardware Fault Tolerance
SFF	Safe Failure Fraction
CCF	Common Cause Failures
PFD _{avg}	Average Probability of Dangerous Failure on Demand
PFH	Probability of a Dangerous Failure per Hour
FMEDA	Failure Mode, Effects and Diagnostics Analysis
λ_{sd}	Rate for safe detected failure
λ_{su}	Rate for safe undetected failure
λ_{dd}	Rate for dangerous detected failure
λ_{du}	Rate for dangerous undetected failure
DC _s	Diagnostics Coverage of safe failures; $DC_s = \lambda_{sd} / (\lambda_{sd} + \lambda_{su})$
DC _D	Diagnostics Coverage of dangerous failures; $DC_D = \lambda_{dd} / (\lambda_{dd} + \lambda_{du})$
FIT	Failure In Time; 1 FIT = 1 failure/10h
MTBF	Mean Time Between Failure
MTTF	Mean Time To Failure
MTTR	Mean Time To Repair
CAT	Category according to EN ISO 13849-1:2023

Tbl. 1: Abbreviations and terms

Other abbreviations and terms are defined in the IEC 61508-4.

5 Relevant norms

IEC 61508 Functional safety of electrical/electronic/programmable electronic safety-related systems. (IEC 61508:2010)

ISO 13849-1 Safety of machinery - Safety-related parts of control systems - Part 1: General principles for design (ISO 13849-1:2023); German version EN ISO 13849-1:2023

6 Safety requirements

Safety integrity level	Operating mode with low requirement rate	Operating mode with high requirement rate
SIL	PFD_{avg}	PFH
4	$\geq 10^{-5} - < 10^{-4}$	$\geq 10^{-9} - < 10^{-8}$
3	$\geq 10^{-4} - < 10^{-3}$	$\geq 10^{-8} - < 10^{-7}$
2	$\geq 10^{-3} - < 10^{-2}$	$\geq 10^{-7} - < 10^{-6}$
1	$\geq 10^{-2} - < 10^{-1}$	$\geq 10^{-6} - < 10^{-5}$

Tbl. 2: Failure limit values for a safety function depending on the SIL class (IEC 61508-1, 7.6.2)

The share of non-hazardous failures	Fault tolerance of the hardware for type B safety-related subsystems (IEC 61508-2, 7.4.3)		
	HFT = 0	HFT = 1	HFT = 2
SFF			
< 60%	Not allowed	SIL1	SIL2
60% – < 90%	SIL1	SIL2	SIL3
90% – < 99%	SIL2	SIL3	SIL4
≥ 99%	SIL3	SIL4	-

Tbl. 3: Hardware fault tolerance, based on the rate of dangerous failures

The vibration monitoring unit model HE205 is a development according to IEC-IEC-61508. The monitoring was developed as a “high-demand system”. It corresponds to a 1oo1 architecture with a diagnostic coverage of > 90%. The diagnostics are permanent and automatic during operation and the start-up phase of monitoring. The monitoring fulfills a safe failure fraction of 90% to < 99% and thus represents a sensor system according to SIL2.

7 Project planning

7.1 Safety functionality

The system includes 3 safety functions:

1. If the measured vibration value exceeds the threshold value set for the pre-alarm for longer than the set delay period, the potential-free pre-alarm semiconductor switch will open (pin 5 and pin 6).
2. If the measured vibration value exceeds the threshold value set for the main alarm for longer than the set delay period, the potential-free main alarm semiconductor switch will open (pin 7 and pin 8).
3. The analogue current output depicts the vibration value measured in the interval between 4 mA and 20 mA.

The vibration value is either the vibration speed or the vibration acceleration depending on the sensor version.

NOTE

The next control unit must trigger the shutdown should the current output deliver more than 20 mA.

7.2 Fail-safe state

When a fault is detected that the sensor cannot correct automatically, the sensor switches to the fail-safe state. The fail-safe state can be recognised when the following 3 conditions occur at the same time:

1. All status LEDs are switched (red, yellow, green).
2. All semiconductor switches are open (as in the de-energised or fault state).
3. The analogue current output supplies 0 mA.

7.3 Event and error code

In fail-safe state, the 4 LED circuits display the 4 most recent event and error codes.

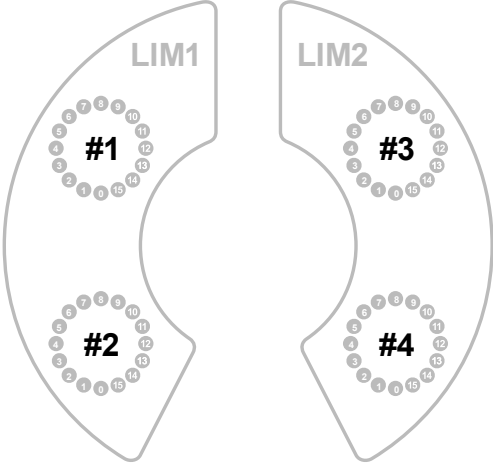
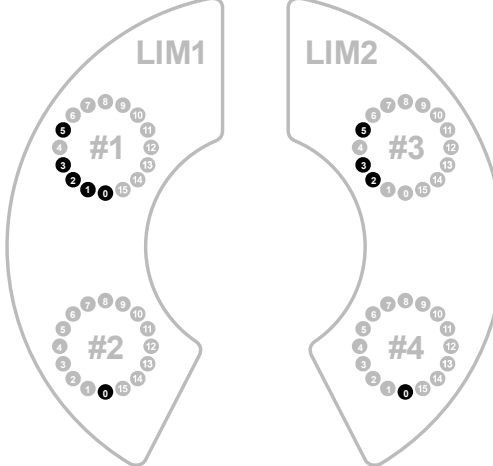
Event/error code sequence	Typical event and error code image
	
<p>(#1 is the newest code and #4 is the oldest code)</p>	

7.4 Most common event and error codes

The event and error codes are displayed in binary code on the LED circuit. An 8-digit binary code is displayed in the LED circuit using the digits 0 to 7. When a digit lights up in the LED circuit, it represents binary 1. When a digit does not light up in the LED circuit, it represents binary 0. The following section presents four of the most common event and error codes by way of illustration.

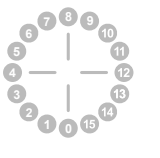
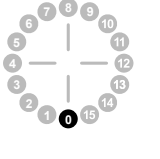
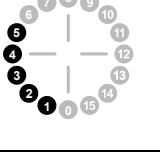
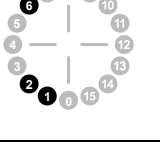
LED circuit	Code	LEDs								Event/error
		7	6	5	4	3	2	1	0	
	0x00	0	0	0	0	0	0	0	0	Initial value
	0x01	0	0	0	0	0	0	0	1	Successful start
	0x3E	0	0	1	1	1	1	1	0	Supply voltage outside of specification
	0x46	0	1	0	0	0	1	1	0	Analogue output feedback measurement outside tolerance
Troubleshooting measures and a complete list of error codes can be found in the following.										

7.5 Exiting the fail-safe state

To return the sensor to its normal operating state, a power cycle must be performed. To do this, the sensor must be de-energised for at least 1 second.

7.6 Event and error code table

For each error, another recommended measure is a power cycle.

LED circuit								Description of event and error codes	Action
7	6	5	4	3	2	1	0		
0	0	0	0	0	0	0	0	Initial value	-
0	0	0	0	0	0	0	1	Successful start	
Supply voltage									
0	0	1	1	1	1	1	0	Supply voltage outside of specification	Check supply voltage
0	0	1	1	1	1	0	1	Internal voltage outside of specification	
0	1	0	0	0	1	0	1	Internal voltage outside of specification	
0	0	1	0	1	0	1	0	Measurement 1 of internal voltage failed	
0	0	1	0	1	0	1	1	Measurement 2 of internal voltage failed	
0	0	1	0	1	1	0	0	Measurement 3 of internal voltage failed	
Analogue output									
0	1	0	0	0	1	1	0	Analogue output feedback measurement outside tolerance	Check connections
0	0	1	0	1	1	1	1	Measurement of analogue output monitoring failed	
Potential-free semiconductor switch / Hex switch									
0	0	1	1	0	0	0	0	Measurement of potential-free semiconductor switch monitoring failed	Check connections
0	0	0	0	1	0	1	1	Hex switches are malfunctioning	Check hex switches
Temperature									
0	0	1	1	1	1	0	0	Temperature outside specification	Check ambient and measuring head temperature
0	0	1	0	1	1	0	1	Measurement 1 of temperature failed	
0	0	1	0	1	1	1	0	Measurement 2 of temperature failed	
Data storage									
0	0	1	1	1	0	0	1	Data storage fault	No action required
0	0	1	1	1	0	1	0	Data storage fault	
For all other error codes, please contact the manufacturer.									

7.7 Configuration safe state

The operator can set the sensor in configuration mode as described in the operating manual. A sensor in configuration mode is not considered to be in a safe state. The safety functions as specified will not operate until configuration has been saved and the sensor is in normal operating mode. The measurement signal is only validated again after leaving the configuration safe mode and meets the requirements for the safety function.

7.8 Description of failure categories









The following definitions for the failure of the device were considered to assess the failure behaviour of the vibration monitoring unit:

- Fail-safe state
Responds to a failure state by switching to a safe state. (fail-safe state)
- Safe Failure ($\lambda_{sd} + \lambda_{su}$)
A safe failure (S) occurs when the measuring system switches to the defined safe state or error mode without requesting the process.
- Dangerous Failure ($\lambda_{dd} + \lambda_{du}$)
A dangerous failure (D) generally occurs when the measuring system switches to a dangerous or non-functional state.
- Dangerous Detected Failure (λ_{dd})
A dangerous detected failure occurs when the measuring system switches to a defined safe state or error mode when a process is requested.
- Dangerous Undetected Failure (λ_{du}):
A dangerous undetected failure occurs when the measuring system does not switch to a defined safe state or error mode when a process is requested.
- Definition of Error Mode:
Error mode is the equivalent to alarm operating mode for the semiconductor switches.

8 Fault exclusions

1. According to ISO 13849-2 (Table D.7), the multi-pole plug connection was chosen to exclude a short circuit between any two adjacent plug pins.

9 Overview of application areas

Coding				HE205.00.xx.xx.xx.00.xxx	HE205.00.xx.xx.xx.01.xxx	HE205.02.xx.xx.xx.00.xxx	HE205.02.xx.xx.xx.01.xxx	HE205.01.xx.xx.xx.00.xxx	HE205.01.xx.xx.xx.02.xxx
Pin assignment	M12 connector		x			x			
	Integrated cable				x		x	x	x
Measuring head temperature T_M Ambient temperature T_A	$-40\text{ °C} \leq T_M \leq 85\text{ °C}$ $-40\text{ °C} \leq T_A \leq 60\text{ °C}$		x			x		x	
	Restriction for the range of application cULus: $-30\text{ °C} \leq T_M \leq 80\text{ °C}$ $-30\text{ °C} \leq T_A \leq 60\text{ °C}$	$-35\text{ °C} \leq T_M \leq 125\text{ °C}$ $-35\text{ °C} \leq T_A \leq 60\text{ °C}$				x		x	
	$-20\text{ °C} \leq T_M \leq 125\text{ °C}$ $-20\text{ °C} \leq T_A \leq 60\text{ °C}$								x
Standard						x	x	x	x
	 Proc. Cont. Eq. Ord. Loc E507077					x	x	x	
Ex Zone 2 and 22	 II 3G Ex ec IIC T4 Gc II 3D Ex tc IIIC 135°C Dc	UL 21 ATEX 2570 X;					x	x	
	 Ex ec IIC T4 Gc Ex tc IIIC 135°C Dc	IECEx ULD 20.0022 Issue 0X; UL-BR 21.1250X						x	x
	 Ex ec IIC T4 Gc Ex tc IIIC T135°C DC	23-AV4BO-0275X 23-AV4BO-0276X						x	x
	 Proc. Cont. Eq. Haz. Loc. Class I, Division 2, Groups A, B, C and D, T4 Class II, Division 2 Groups F and G, T4	E516625						x	x
	CCC Ex nA IIC T4 Gc Ex tD A22 IP66/67 T135°C	No: 2021122315114599						x	x
Ex Zone 1 and 21	 II 2G Ex db IIC T4 Gb II 2D Ex tb IIIC 135°C Db	UL 20 ATEX 2421 X;						x	x
	 Ex db IIC T4 Gb Ex tb IIIC 135°C Db	IECEx ULD 20.0022 Issue 0X; UL-BR 21.1250X							x
	 Ex db IIC T4 Gb Ex tb IIIC T135°C Db	23-AV4BO-0277X 23-AV4BO-0278X							x
	CCC Ex d IIC T4 Gb Ex tD A21 IP66/67 T135°C	No: 2021122315114599							x

10 Example labels

Variant 1 - HE205.00.xx.xx.xx.xxx

<p>Type: HE205.00.xx.xx.xx.xxx Item-no.: 12345 Ver.: 2.0 Serial-no.: 123456 / 2025 Measuring range: 0...xxx mm/s, x-rms Frequency range: xx...xxxx Hz -xx °C ≤ T-amb ≤ +xx °C</p>		<p>ES1625 Prot. Const. Eq. Ord. Loc.</p>	<p>18...27 V DC / ≤ 100 mA IP 66/67 Type 4x Enclosure</p>			Manufacturer: HAUBER-Elektronik GmbH Fabrikstraße 6 72622 Nürtingen Germany www.hauber-elektronik.de

Variant 2 - HE205.02.xx.xx.xx.xxx

<p>Type: HE205.01.xx.xx.xx.xxx Item-no.: 12345 Ver.: 2.0 Serial-no.: 123456 / 2025 Measuring range: 0...xxx mm/s, x-rms Frequency range: xx...xxxx Hz -xx °C ≤ T-amb ≤ +xx °C</p>		<p>ES1625 Prot. Const. Eq. Ord. Loc.</p>	<p>18...27 V DC / ≤ 100 mA IP 66/67 Type 4x Enclosure</p>			Manufacturer: HAUBER-Elektronik GmbH Fabrikstraße 6 72622 Nürtingen Germany www.hauber-elektronik.de

Variant 3 - HE205.01.xx.xx.xx.xxx

<p>Type: HE205.02.xx.xx.xx.xxx Item-no.: 12345 Ver.: 2.0 Serial-no.: 123456 / 2025 Measuring range: 0...xxx mm/s, x-rms Frequency range: xx...xxxx Hz -xx °C ≤ T-amb ≤ +xx °C</p>		<p>ES1625 Prot. Const. Eq. Ord. Loc.</p>	<p>18...27 V DC / ≤ 100 mA IP 66/67 Type 4x Enclosure</p>			Manufacturer: HAUBER-Elektronik GmbH Fabrikstraße 6 72622 Nürtingen Germany www.hauber-elektronik.de

11 Connection

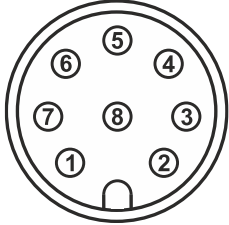
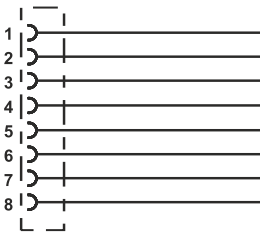
Version:	M12 connector	
	Pin 1:	24 V DC
	Pin 2:	GND
	Pin 3:	4-20 mA output signal
	Pin 4:	NC (not connected)
	Pin 5:	Potential-free semiconductor switch 1 +
	Pin 6:	Potential-free semiconductor switch 1 -
	Pin 7:	Potential-free semiconductor switch 2 +
	Pin 8:	Potential-free semiconductor switch 2 -
Version:	Integrated cable	
	Pin 1:	white 24 V DC
	Pin 2:	brown GND
	Pin 3:	green 4-20 mA output signal
	Pin 4:	yellow NC (not connected)
	Pin 5:	grey Potential-free semiconductor switch 1 +
	Pin 6:	pink Potential-free semiconductor switch 1 -
	Pin 7:	blue Potential-free semiconductor switch 2 +
	Pin 8:	red Potential-free semiconductor switch 2 -

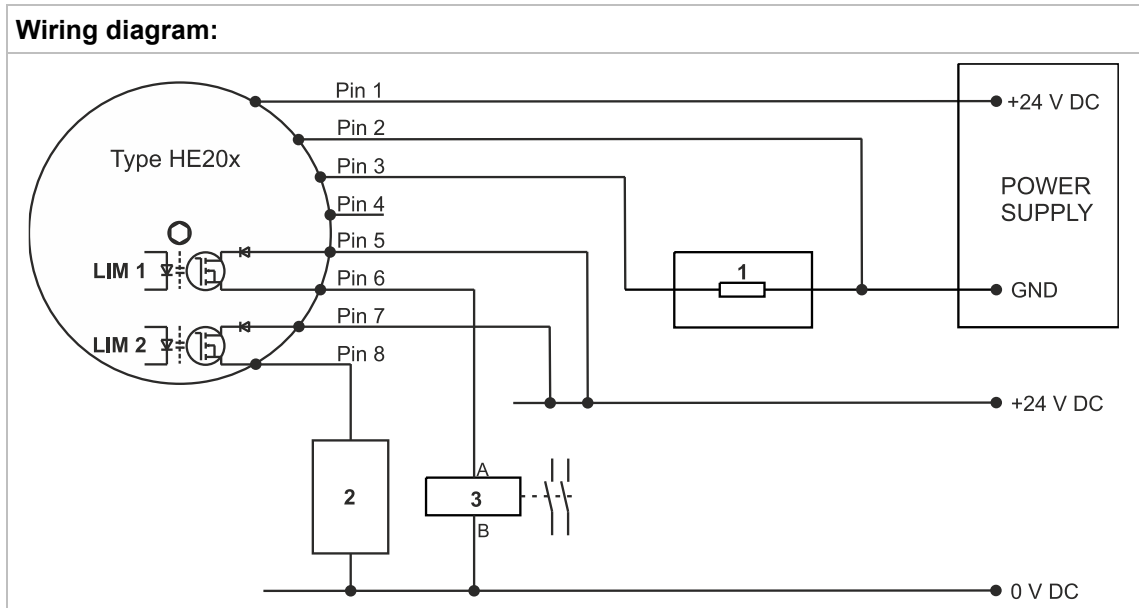

Fig. 1: Wiring diagram

- LIM 1 Potential-free semiconductor switch 1 (unidirectional, pin 5: + , Pin 6: -)
- LIM 2 Potential-free semiconductor switch 2 (unidirectional, pin 7: + , Pin 8: -)
- 1 Analogue input (4-20 mA) of an evaluation unit (e.g. safety controller, PLC, etc.)
- 2 Application example: Digital input (I/O) of a safety controller
- 3 Application example: Safety relay



The potential-free semiconductor switches LIM 1 and LIM 2 are blocking ('open') in alarm state or de-energised state.



If the power output is not required, pin 3 must be connected to GND.

12 Assembly and installation

Pay attention to the assembly and installation notes in the operating manual. To do this, select threshold value settings so that the safety function is triggered before any damage can be done to the system.

The sensor must be powered by a SELV power supply in safe operation.

13 Functional description



In an explosive atmosphere, the vibration monitoring unit HE205 will only be opened in a de-energised state.

The type HE205 is used for monitoring vibration acceleration.

If the acceleration value is below or above the adjustable window area, an alarm will be triggered. The vibration monitoring unit contains two channels independent from each other, LIM1 and LIM2. The lower limit value of the window area is adjusted on LIM1 and the upper limit value is adjusted on LIM2 (see chart).

The HE205 type also has an analogue current output. This supplies direct current of 4-20 mA proportional to the vibration amplitude.

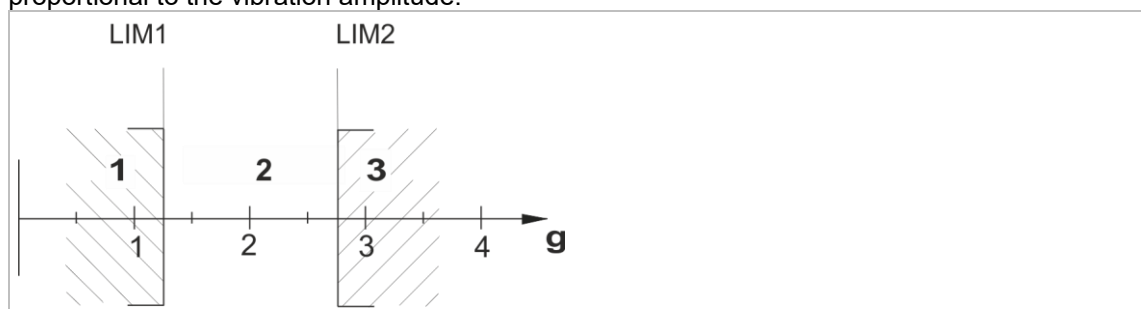

Fig. 2: Window function

- 1 Alarm for values below LIM1
- 2 Window area
- 3 Alarm for values above LIM2

13.1 Operating conditions

Operating state	Measured value	Semiconductor switches	Status LEDs	LED circuits
OK	≤ limit value	Closed	green	Setting accepted (permanently on)
WARNING	> Limit value, delay time runs	Closed	green + yellow	Setting accepted (permanently on)
ALARM	> Limit value, delay time expired	Open	red	Setting accepted (permanently on)
Fail-safe state	0 mA	Open	red + yellow + green	Event and error codes (permanently on)
Configuration mode (Config Safe State)	0 mA	undefined	undefined	Setting not accepted (flashing)
De-energised	0 mA	Open	All LEDs off	all LEDs off

Tbl. 4: Operating conditions

13.2 Configuration mode (alarm and limit setting)



While the sensor is in configuration mode, the safety functions are deactivated.

By pressing the “Save Config” button, the current configuration is displayed by the LEDs around the HEX switches.

The limit values and delay times are calibrated using the respective HEX switch. As soon as a switch position is changed, all LEDs start flashing. Press and hold the **“Save Config” button for three seconds** to save the configuration. Acceptance of the configuration is signalled by steady lighting up of the LEDs in the selected HEX switch position.

The configuration can only be accepted if $LIM1 \leq LIM2$.

After five minutes, the LEDs turn off automatically.

13.3 Limit values and delay times

The **SET rotary button** has 16 positions, representing the limit value of an alarm. The measuring range of the vibration monitoring unit is divided into 16 linear steps.

In general: $Grenzwert = \frac{Messbereich\ Obergrenze}{16} \times SET\ Position$

Example: Limit setting

Measuring range: 0–4 g
 SET rotary button Pos.: 8 (9)
 Limit value: 2 g (2.25 g)

SET Position ↓	Limit values (g)						
	Measu- ring range →	0-1 g	0-2 g	0-4 g	0-6 g	0-8 g	0-10 g
0		0	0	0	0	0	0
1		0.063	0.125	0.25	0.375	0.5	0.625
2		0.125	0.25	0.5	0.75	1	1.25
3		0.188	0.375	0.75	1.125	1.5	1.875
4		0.25	0.5	1	1.5	2	2.5
5		0.313	0.625	1.25	1.875	2.5	3.125
6		0.375	0.75	1.5	2.25	3	3.75
7		0.438	0.875	1.75	2.625	3.5	4.375
8		0.5	1	2	3	4	5
9		0.563	1.125	2.25	3.375	4.5	5.625
10		0.625	1.25	2.5	3.75	5	6.25
11		0.688	1.375	2.75	4.125	5.5	6.875
12		0.75	1.5	3	4.5	6	7.5
13		0.813	1.625	3.25	4.875	6.5	8.125
14		0.875	1.75	3.5	5.25	7	8.75
15		0.938	1.875	3.75	5.625	7.5	9.375

Tbl. 5: Limit values

Delay times

TIME Position	0	1	2	3	4	5	6	7	8	9	10	11	12	13	14	15
Delay time (secs)	0	1	2	3	4	5	7.5	10	12.5	15	17.5	20	25	30	45	60

Tbl. 6: Delay times

14 Behaviour during operation and when errors occur

The set elements and/or device parameters should not be changed during operation. If set elements and/or device parameters are changed during operation, the operator must ensure the safety of the system! Occurring errors are described in the fault table in the operating manual. If errors are detected, the entire vibration monitoring unit must be taken out of operation and other measures must be taken to keep the process in a safe state. The operating manual describes how to replace the vibration monitoring unit.

15 Self-diagnostic and recurring checks

The sensor has a set of self-diagnostic measures. These are divided into 2 categories:

1. Start-up diagnostic:

These tests are only run in the sensor's initial start-up phase. Among other things, hardware-critical pathways are tested here that cannot be switched off once the device is in operation. One of these critical tests is the diagnostic for the pre-alarm and main alarm switching outputs. In order to ensure the functionality of the switching outputs over the product's service life, the system operator must make sure to cycle the power on the vibration monitoring unit once a year.

2. Cyclical monitoring:

Cyclical monitoring is fully automated and ensures that all tests are performed and evaluated within 12 hours for a diagnostics coverage of >90%.

16 Service life

The measuring system has a service life of 10 years.

17 Key indicators related to safety

Failure category	Failure rate (FIT)
Σλ Safe / Fail Safe Detected (λSD)	600
Σλ Dangerous / Fail Dangerous Detected (λDD)	350
Σλ no part	80
Σλ Total	1030
Σλ Dangerous Detected / Fail Dangerous Detected (λDD)	350
Σλ Dangerous Undetected / Fail Dangerous Undetected (λDU)	15

SFF (Type B) SF	93.24%
SIL	2
Performance Level	D
Category	2
PFD	$9,2463 \cdot 10^{-4}$
PFH	$<2 \cdot 10^{-7}$ 1/h With an average expected requirement rate of fewer than 25 times per year
Diagnostics coverage	>90%

Tbl. 7: Failure rates

MTTF	984898hrs = 112.43 years
DC _{avg}	>90% Diagnostics Coverage
MTTF _d	2889526hrs = 329.85 years = HIGH
CCF	95 (fulfilled)
Response time	200 ms

Tbl. 8: Key indicators related to safety according to ISO 13849-1

18 EU Declaration of Conformity

Declaration of conformity

HAUBER-Elektronik GmbH
 Fabrikstrasse 6
 D-72622 Nürtingen, Germany

declares under our sole responsibility that the products listed below that relate to this declaration meet the basic health and safety requirements of the norms and directives below.

Product series

HE200, HE205

ATEX Annex

UL International Demko A/S certifies as **Notified Body No. 0539** according to the Directive of the Council of the European Community of 26 February 2014 (2014/34/EU) that the manufacturer maintains a quality assurance system for production that complies with Annex IV of this Directive.

Affixed CE marking

CE 0539

Norms and directives

EU Directive	Norms
2014/30/EU /	EN 61000-6-3:2007 + A1:2011 EN 61000-6-2:2005 + AC:2005-09 EN 55011:2016 + A1:2017 + A11:2020 <i>Supplementary:</i> EN 61000-6-7:2015
2014/34/EU /	EN IEC 60079-0:2018 + AC:2020-02 EN 60079-1:2014 + AC:2018-09 EN IEC 60079-7:2015 + A1:2018 EN 60079-31:2014
2011/65/EU /	EN IEC 63000:2018

Marking and certificates

HE200.02 / HE205.02

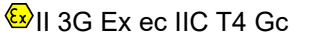
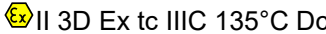
Marking	Certificate
 	ATEX: UL 21 ATEX 2570 X

HE200.01 / HE205.01

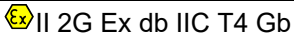
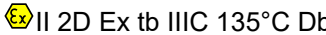
Marking	Certificate
 	ATEX: UL 20 ATEX 2421 X Rev. 0

Signature

Nürtingen, Germany 04.12.2025

Place and date



Tobias Bronkal, Managing Owner